



ZR525-CSI

5.25-inch (130 mm) 2-Way Component System

owner's manual

Thank you for choosing a JL Audio Evolution ZR Component System for your automotive sound system. With proper installation, your new speakers will deliver years of listening pleasure.

We strongly recommend that you have your new Evolution speakers installed by your authorized JL Audio dealer. The installation professionals employed by your dealer have the necessary tools and experience to disassemble your interior panels, install your new speakers and reassemble your vehicle properly. If you prefer to perform your own installation, please read this instruction manual completely before beginning the process.

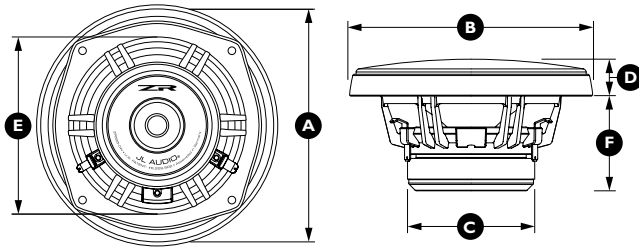

Woofer Physical Dimensions	
Frame Outer Diameter (A)	5.80 in. / 147.3 mm
Grille Tray Outer Diameter (B)	6.02 in. / 152.9 mm
Magnet Outer Diameter (C)	3.15 in. / 80.0 mm
Frontal Grille Protrusion (D)	0.92 in. / 23.5 mm
Mounting Hole Diameter (E)	4.48 in. / 113.8 mm
Mounting Depth (F)	2.34 in. / 59.3 mm

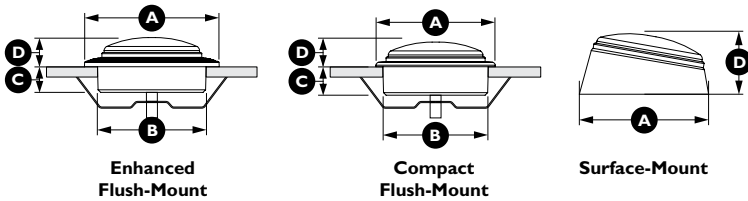

Tweeter Fixture Physical Dimensions	Enhanced Flush-Mount	Compact Flush-Mount	Surface-Mount
Mounting Fixture Outer Diameter (A)	2.13 in. / 54.0 mm	1.90 in. / 48.3 mm	1.82 in. / 46.2 mm
Mounting Fixture Mounting Hole Diameter (B)	1.72 in. / 43.5 mm	1.68 in. / 42.6 mm	N/A
Fixture Mounting Depth (C)	0.40 in. / 10.3 mm	0.45 in. / 11.5 mm	N/A
Tweeter Frontal Protrusion (D)	0.46 in. / 11.7 mm	0.39 in. / 9.9 mm	0.85 in. / 21.6 mm

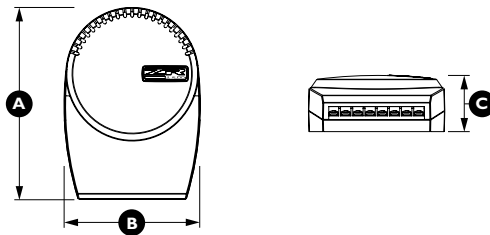

Crossover Network Physical Dimensions	
Height (A)	5.86 in. / 148.9 mm
Width (B)	4.17 in. / 105.8 mm
Depth (C)	1.68 in. / 42.8 mm

ZR525-CSI SPECIFICATIONS:

Woofers: Mineral-filled polypropylene cone body, 1-inch (25mm) voice coil, low-profile/ symmetrical-roll spider; butyl rubber surround

Tweeters: 1-inch (25 mm) aluminum dome tweeter with soft rubber suspension, neodymium magnet, ferrofluid cooled and damped, variable mounting system

Crossover Networks: 2-way network with 1st order low-pass and 2nd order high-pass circuit, premium polypropylene film capacitors, air-core inductors and non-inductive Mills™ resistors, 5-position adjustable tweeter output level, 4-position midrange presence control, Polyswitch tweeter protection

Continuous Power Handling: 75 Watts (RMS Method)

Peak Music Power: 225 Watts

Recommended Power Range: 25-150 Watts (RMS)

Frequency Response: 53 Hz - 25 KHz (± 3 dB)

Efficiency @ 1W/1m: 89.5 dB

Nominal Impedance: 4 ohms

Included Components and Parts:

- Two ZR525-CWi 5.25-inch (130 mm) Woofers
- Two ZR100-CT 1-inch (25 mm) Tweeters
- Two ZR525-CSpxo Crossover Networks
- Two Compact Flush-Mount Tweeter Fixtures
- Two Enhanced Flush-Mount Tweeter Fixtures
- Two Surface-Mount Tweeter Fixtures
- Two Metal Woofer Grilles with ABS Grille Trays
- Two Self-Adhesive ZR Nameplates for Grilles
- Butyl Adhesive Putty for Woofer Grilles
- Twelve #8 x 1.25 inch (30 mm) Sheet Metal Screws
- Four #6 x 1-inch (25 mm) Sheet Metal Screws
- Two 1.18-inch (30 mm) Machine Screws
- Two Metal Spring Clips for Tweeter Fixtures
- Eight Mounting Clips for Woofer Mounting
- Two 6.4 mm Female Crimpable Connectors
- Two 4.7 mm Female Crimpable Connectors
- Four 2.8 mm Male Crimpable Connectors
- Twelve Crimpable Spade Connectors

All specifications are subject to change without notice.

GETTING STARTED:

- Turn off the audio system. It is also advisable to disconnect the negative (–) terminal of your vehicle's battery whenever performing installation work.
- Before cutting, drilling or inserting any screw, check clearances on both sides of the planned mounting surface. Also check for any potential obstacles, such as window tracks and motors, wiring harnesses, etc. Check both sides of the vehicle, many vehicles are not symmetrical!
- Always wear protective eyewear.

CROSSOVER NETWORK INSTALLATION:

The crossover networks supplied with your ZR System should be installed in a dry location inside your vehicle. **DO NOT INSTALL THEM INSIDE OF A DOOR!** Doors often get wet on the inside, which can damage your crossover networks and could potentially damage your entire sound system. The crossovers can be screwed into a solid surface via two holes located under the protective cover of the case. To access these holes, simply squeeze the sides of the cover while gently pulling the cover away from the base. Make sure that your mounting location will not cause damage to wiring, fuel lines, brake lines or any other vital component of your vehicle. Once you have screwed the case in and made your connections, snap the protective cover back into place.

!!	WARNING	!!
<p>It is absolutely vital that your component system is connected as shown in this manual. Failure to connect the system as shown may result in damage to your speakers which is NOT covered under warranty.</p> <p>Do not substitute different crossover networks into your ZR System. Do not use crossover networks intended for different ZR models.</p>		

WIRING DIAGRAMS - STANDARD AND BI-AMP / BI-WIRE METHODS:

The input to the crossover networks can be set up in one of the following two ways:

Standard: This wiring configuration is used when you wish to drive each crossover with a single amplifier channel or pair of wires. In this mode, you will only use the input connections marked "INL+" and "INL–" on the crossover circuit board ("INH+" and "INH–" are not used). **Your crossovers are pre-set in this mode at the factory.** This mode is selected by placing the pair of jumper bars shown in Diagram A to the lower position marked "STD". Tweeter ("T+" and "T–") and woofer output connections ("W+" and "W–") are made as shown in Diagram A.

Bi-Wire (Bi-Amp): This position is selected by placing the input mode selection jumper bars in the upper position as shown in Diagram B. In this mode, the inputs to the woofer's low-pass filter and the tweeter's high-pass filter are electrically isolated. This permits connection of different amplifier channels to the woofer and tweeter sections (bi-amp), or separate wire pairs for each section from a single amplifier channel (bi-wire). In this mode, you will use the Input connections marked "INL+" and "INL–" to drive the low-pass woofer section of the crossover and "INH+" and "INH–" to drive the high-pass tweeter section of the crossover. Tweeter ("T+" and "T–") and woofer output connections ("W+" and "W–") are made as shown in Diagram B.

Please note that the use of additional active filtering for the woofer low-pass or tweeter high-pass is not necessary or recommended in this mode. The crossover network has been engineered to shape the system response... additional filters may degrade performance.

Diagram A: Standard Wiring Diagram

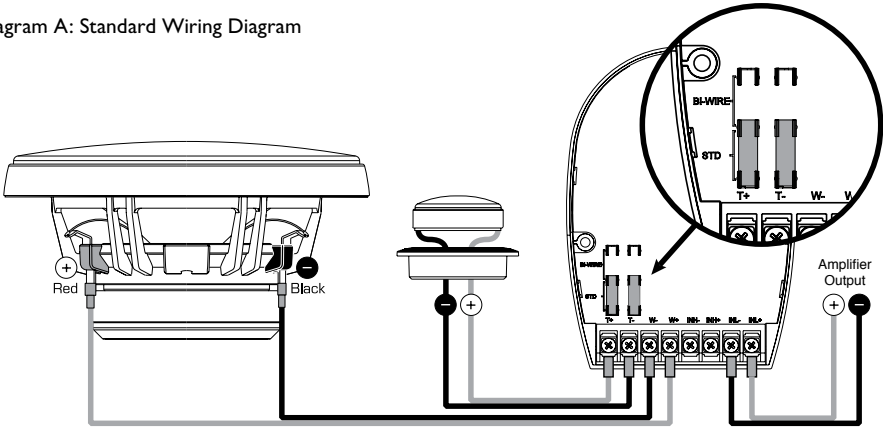
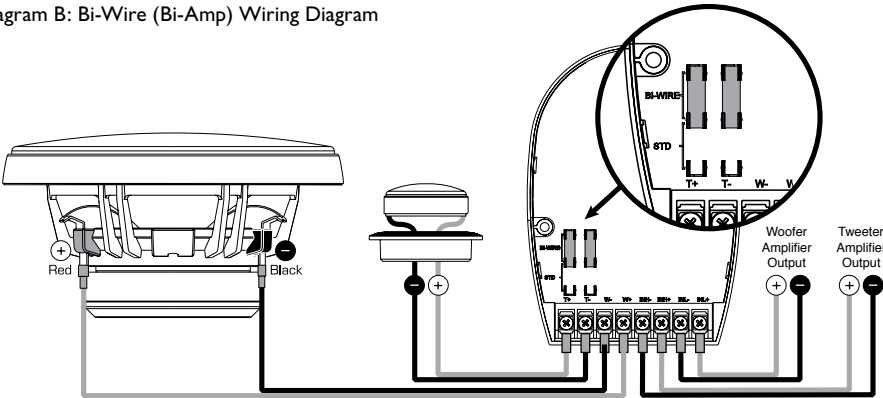

Diagram B: Bi-Wire (Bi-Amp) Wiring Diagram



CROSSOVER NETWORK ADJUSTMENT

The ZR crossover networks have been designed to allow tonal adjustments to the upper midrange response and tweeter level. These adjustments make it possible to fine-tune your system to suit your listening preferences and to compensate for various speaker mounting applications.

ADJUSTABLE MIDRANGE PRESENCE:

Your ZR crossover networks provide a unique midrange presence control, located under the clear cover. The midrange presence is selectable via a set of pins and allows for four settings. These settings affect the amplitude of the upper midrange response of the ZR component woofer. We recommend that you begin your listening with the factory setting (3) and adjust up or down as needed to compensate for mounting location, orientation or personal taste.

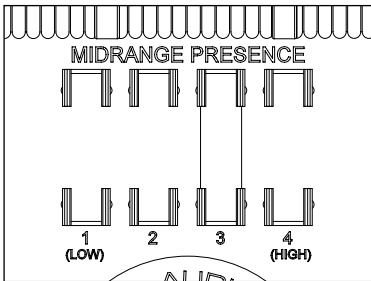

ADJUSTABLE TWEETER LEVEL:

ZR crossover networks also provide five levels of tweeter adjustability designed to compensate for different mounting locations, vehicle interiors and personal taste. These levels are selectable via a set of pins located under the clear cover of each crossover case. We recommend that you begin listening in the "REF" (Reference) position. To find the optimum tonal balance in your installation, experiment with alternate tweeter level settings by moving the jumper connector. It is safe to switch jumpers while the system is playing.

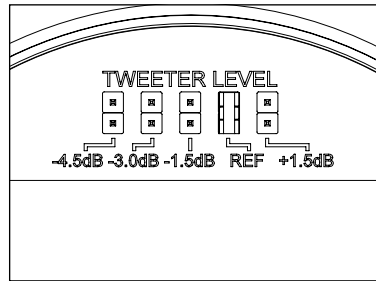

TWEETER PROTECTION:

The ZR crossover networks are equipped with an advanced electronic tweeter protection circuit designed to minimize the possibility of tweeter failure. This electronic device monitors current going to the tweeter and will disconnect the tweeter from the signal when it senses overload. Should this occur while listening to the audio system, simply reduce the volume for a few seconds and the protection circuit will reset itself automatically.

SPEAKER PLACEMENT CONSIDERATIONS:

A component system gives you the ability to place the woofer and tweeter separately in your vehicle interior. This can be good or bad, depending on how it's done. As a general rule, the tweeters should be placed relatively close to the woofers for best tonal balance and most coherent imaging (the closer, the better). Any separation greater than 8 inches (20 cm) is likely to result in degraded sound quality.

Avoid placing tweeters where they will be blocked by objects in the interior of the car (including seated occupants). When selecting a mounting location, look at both sides of the car to make sure that this location is clear on both sides.

You can always experiment with tweeter placement before committing to a final mounting location. Simply connect the rest of the system and allow plenty of wire length for the tweeters. Using Velcro® or similar material, attach the tweeters in different locations until you find the one where they perform best.

Woofers will usually be placed into factory speaker locations. If you have some woofer mounting flexibility, keep the following in mind: Lower mounting locations, such as the lower front corner of a door or a kick-panel provide the greatest path length distances for the sound emitted by the woofer. For this reason, they are generally more desirable than higher mounting locations. Higher mounting locations often result in extreme near-side soundstage bias which compromises the stereo listening experience.

Less Desirable Speaker Placement

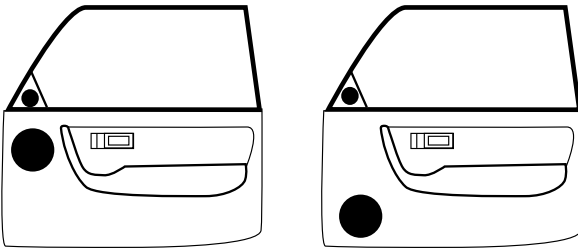

More Desirable Speaker Placement

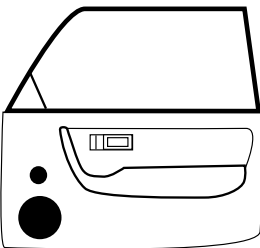



WARNING



Double check the clearance for both speakers before proceeding. Many cars are different from one side to the other!

WOOFER INSTALLATION:

The woofers should be installed in one of the following ways depending on location:

Factory Location: If you will be using the factory speaker wires, it may be necessary to change the terminations. This may be accomplished by using an adaptor plug or simply by cutting the factory connector off and using the supplied crimp connectors to terminate the speaker wires. The large connector is for the positive (+) terminal and the small connector is for the negative (-) terminal of each woofer. **Keep in mind that the woofer wires must be connected to the woofer outputs of the crossovers supplied with your system as shown in the diagram on page 5.** If you prefer to run new wires, refer to the "Custom Location" installation section for details. Whichever method you choose, observe correct polarity in your connections. If you are unsure about any of these issues, contact your JL Audio dealer for installation assistance.

Your new speakers have been designed to install, without modifications, into most vehicles that accept a 5.25-inch (130 mm) speaker. Most factory 5.25-inch speakers use four mounting screws which will line up with the mounting holes on your woofers.

It is absolutely vital that the speaker frame fits into the mounting hole cleanly. This must be checked prior to tightening the screws. Do not force the frame into a hole that is too small. Do not tighten the speaker onto an uneven surface. This will damage your speakers. The speaker should also fit so that air does not leak around the mounting flange. Air leaks will cause a severe degradation in sound quality. Seal any air leaks with an automotive-grade sealant material.

Use the supplied mounting clips unless the factory holes already feature threaded inserts.

Hand-tighten the screws evenly.

Custom Location: Run speaker wire to the desired mounting locations. If you are running wires into a door, use existing factory wiring boots whenever possible. If you are drilling new holes, file their edges and install rubber grommets into each hole. Wires should then be covered with a protective, flexible PVC sleeve and then run through the door jamb. Make sure that the wires will clear door hinges and other structures in the door. If you are unsure about any part of this process, please contact your JL Audio dealer for installation help.

Select an even surface. Tightening a speaker onto an uneven surface can damage it. Carefully measure and mark the "mounting hole diameter" outline in the selected location using the dimensions listed on page 2. Before drilling or cutting on your interior panels, use a utility knife to cut any fabric, vinyl or leather from hole locations. These materials can easily be snagged by a drill or a saw, causing damage to the panel and possible bodily injury. Drill a pilot hole in the center of the proposed speaker mounting hole. Then, using a saber saw with an appropriate blade, make the circular cut out for the speaker. File any rough edges.

After cutting the hole, check to see that the speaker frame fits into its mounting hole cleanly. Do not force the frame into a hole that is too small. Once the speaker is in place, use the holes on the speaker's mounting flange to mark the panel where the four mounting screws will be positioned, as shown in Diagram D. Remove the speaker and drill 1/8-inch (3 mm) holes at each mark. Insert the mounting clips with the flat side towards the speaker. Connect the speaker wires, observing correct polarity, and secure the speaker and grille tray to the panel by evenly tightening by hand the provided #8 x 1.25 inch (16 mm) mounting screws. Make sure the woofer is secured so that air does not leak around the mounting flange. Air leaks will cause a severe degradation in sound quality. Seal any air leaks with an automotive-grade sealant material.

Break off small pieces of the supplied butyl adhesive putty and place them on the inside of each grille tray. This adhesive will hold the grille mesh insert in place firmly and prevent rattling. Then insert the grille mesh insert into the grille tray, squeezing gently around its edge until it seats firmly into the tray.

Finally, attach the self-adhesive ZR logo badge to the grille mesh insert.

Diagram C: Factory Location Woofer Installation

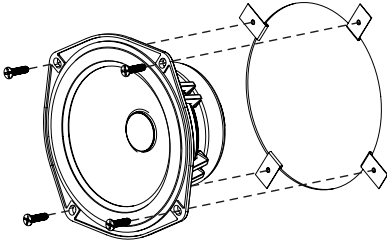
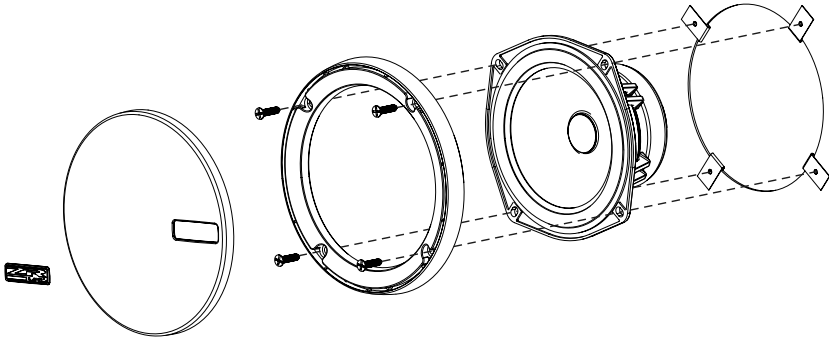

Diagram D: Custom Location Woofer Installation



!!	WARNING	!!
Hand-tighten the screws evenly in a criss-cross pattern to avoid bending the speaker frame or stripping the mounting clips.		

TWEETER INSTALLATION:

First, run speaker wires from the tweeter output of the crossover (see diagrams on page 5) to the desired tweeter mounting locations, observing the same precautions as mentioned in the woofer installation section. Terminate the wires with the supplied 2.8 mm male crimpable connectors.

TWEETER FIXTURE INSTALLATION:

The dome tweeters supplied with your ZR525-CSi system have been designed for maximum mounting versatility. There are two primary methods by which the tweeters can be mounted in your vehicle:

Flush-Mount: Two different styles of flush-mount fixtures are provided: a compact, simple design and an enhanced design. Both are installed using the same method (shown in Diagram E), but require different size mounting cutouts. Refer to page 2 for cutout dimensions.

Flush-mounting yields a custom-installed appearance, but will require at least 3/4-inch (19 mm) of clearance behind the mounting surface of the tweeter. Install as shown in Diagram E, using the spring clips and 1-inch machine screws (it may be necessary in some limited depth applications to cut down the length of the machine screw, or use a shorter screw (not supplied)). Hand-tighten the machine screw until the fixture is secure.

Surface-Mount: In this application, you will not need to cut large holes in your vehicle's panels for the tweeters. You will only need to drill a hole for the wires and two smaller holes for the mounting screws. This application is useful when mounting the tweeters to a panel that has insufficient clearance behind it for the tweeter's magnet structure.

Using the fixture as a template, mark the screw hole locations and a location in the center of the fixture for the wire hole. Remove the fixture and drill pilot holes for the screws and a 1/8-inch (3 mm) for the wires. Use the supplied #6 x 5/8-inch sheet metal screws to secure the fixture as shown in Diagram F (hand-tighten). Run the tweeter's wires through the hole and insert the tweeter until it snaps into place.

Diagram E: Flush-Mount Tweeter Installation

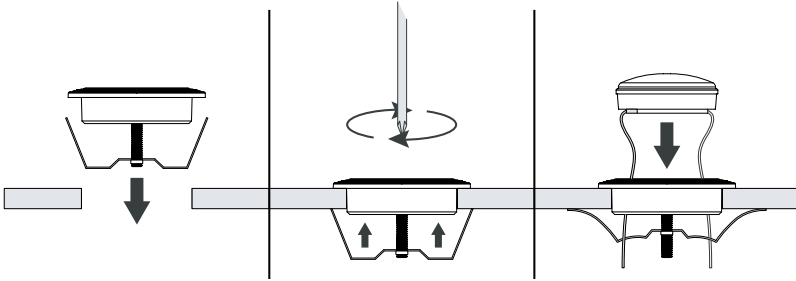
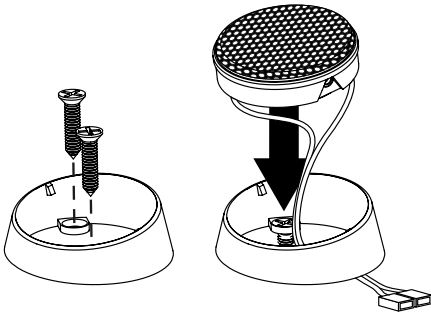

Diagram F: Surface-Mount Tweeter Installation



JL AUDIO LIMITED WARRANTY (USA)

Automotive Speaker Systems

JL Audio warrants these speakers (and crossover networks, where applicable) to be free of defects in materials and workmanship for a period of **one (1) year**.

This warranty is not transferrable and applies only to the original purchaser from an authorized JL Audio dealer. Should service be necessary under this warranty for any reason due to manufacturing defect or malfunction, JL Audio will, at its discretion, repair or replace the defective product with new or remanufactured product at no charge.

Damage caused by the following is not covered under warranty: accident, misuse, abuse, product modification or neglect, failure to follow installation instructions, unauthorized repair attempts, misrepresentations by the seller. This warranty does not cover incidental or consequential damages and does not cover the cost of removing or reinstalling the unit(s). Cosmetic damage due to accident or normal wear and tear is not covered under warranty.

Any applicable implied warranties are limited in duration to the period of the express warranty as provided herein beginning with the date of the original purchase at retail, and no warranties, whether express or implied, shall apply to this product thereafter. Some states do not allow limitations on implied warranties, therefore these exclusions may not apply to you. This warranty gives you specific legal rights, and you may also have other rights which vary from state to state.

If you need service on your JL AUDIO product:

All warranty returns should be sent to JL Audio freight prepaid through an authorized JL Audio dealer and must be accompanied by proof of purchase (a copy of the original sales receipt.) Direct returns from consumers or non-authorized dealers will be refused unless specifically authorized by JL Audio with a valid return authorization number. Warranty expiration on products returned without proof of purchase will be determined from the manufacturing date code. Coverage may be invalidated as this date is previous to purchase date. Return only defective components. If one speaker fails in a system, return only that speaker component, not the entire system. Non-defective items received will be returned freight-collect. Customer is responsible for shipping charges and insurance in sending the product to JL Audio. Freight damage on returns is not covered under warranty.

For Service Information in the U.S.A. please call:

JL Audio customer service: (954)443-1100
during normal business hours (Eastern Time)

JL Audio, Inc

10369 North Commerce Pkwy.
Miramar, FL 33025

International Warranties:

Products purchased outside the United States of America are covered only by that country's distributor and not by JL Audio, Inc.